

PRESSURE FILTER, manifold mounted

Series HPF 60 - 450 DN 18 - 28 PN 315

Sheet No.
1473 Q

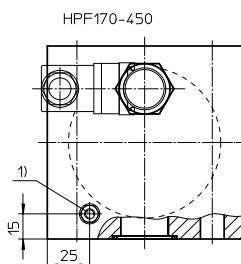
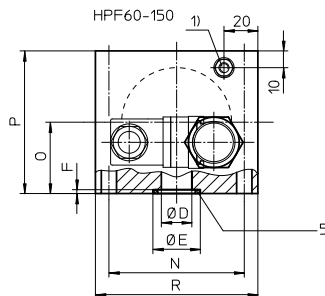
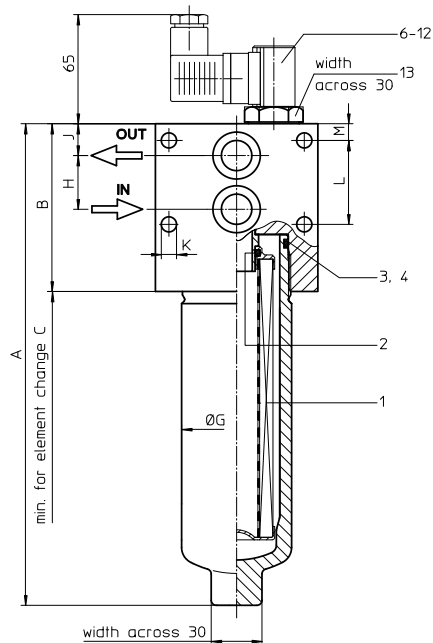

¹⁾ connection for the potential equalisation, only for application in the explosive area

1. Type index:

1.1. Complete filter: (ordering example)

HPF. 90. 10VG. HR. E. P. - . F. 4. - . - . AE

1	2	3	4	5	6	7	8	9	10	11	12
---	---	---	---	---	---	---	---	---	----	----	----

- 1 **series:**
HPF = pressure filter, manifold mounted
- 2 **nominal size:** 60, 90, 150, 170, 240, 360, 450
- 3 **filter-material and filter-fineness:**
80 G = 80 µm, 40 G = 40 µm, 25 G = 25 µm stainless steel wire mesh
25 VG = 20 µm_(c), 16 VG = 15 µm_(c), 10 VG = 10 µm_(c),
6 VG = 7 µm_(c), 3 VG = 5 µm_(c) Interpor fleece (glass fibre)
- 4 **resistance of pressure difference for filter element:**
30 = Δp 30 bar
HR = Δp 160 bar (rupture strength Δp 250 bar)
- 5 **filter element design:**
E = single-end open
- 6 **sealing material:**
P = Nitrile (NBR)
V = Viton (FPM)
- 7 **filter element specification: (see catalog)**
- = standard
VA = stainless steel
IS06 = see sheet-no. 31601
- 8 **connection:**
F = manifold mounted
- 9 **connection size:**
4 = DN 18 (HPF 60-150)
5 = DN 28 (HPF 170-450)
- 10 **filter housing specification: (see catalog)**
- = standard
IS06 = see sheet-no. 31605
- 11 **internal valve:**
- = without
S1 = with by-pass valve Δp 3,5 bar
S2 = with by-pass valve Δp 7,0 bar
R = reversing valve, Q ≤ 70,06 l/min (HPF 60-150)
Q ≤ 211,008 l/min (HPF 170-450)
- 12 **clogging indicator or clogging sensor:**
- = without
AOR = visual, see sheet-no. 1606
AOC = visual, see sheet-no. 1606
AE = visual-electrical, see sheet-no. 1615
VS1 = electronical, see sheet-no. 1617
VS2 = electronical, see sheet-no. 1618

2. Dimensions:

type	HPF 60	HPF 90	HPF 150	HPF 170	HPF 240	HPF 360	HPF 450
connection	DN18	DN18	DN18	DN28	DN28	DN28	DN28
A	218	283	392	330	380	460	565
B	96	96	96	140	140	140	140
C	270	335	445	350	400	480	585
D	18	18	18	28	28	28	28
E	28	28	28	38	38	38	38
F	2,3	2,3	2,3	1,8	1,8	1,8	1,8
G	65	65	65	90	90	90	90
H	32	32	32	44	44	44	44
J	19	19	19	28	28	28	28
K	9	9	9	14	14	14	14
L	50	50	50	44	44	44	44
M	10	10	10	28	28	28	28
N	80	80	80	80	80	80	80
O	42,5	42,5	42,5	57,5	57,5	57,5	57,5
P	85	85	85	115	115	115	115
R	96	96	96	115	115	115	115
volume tank	0,3 l	0,4 l	0,6 l	0,7 l	0,9 l	1,2 l	1,6 l

1.2. Filter element: (ordering example)

01E. 90. 10VG. HR. E. P. -

1	2	3	4	5	6	7
---	---	---	---	---	---	---

- 1 **series:**
01E. = filter element according to company standard
- 2 **nominal size:** 60, 90, 150, 170, 240, 360, 450
- 3 - 7 see type index-complete filter

EDV 08/12

Changes of measures and design are subject to alteration!

3. Spare parts:

item	qty.	designation	dimension and article-no.	
			HPF 60-150	HPF 170-450
1	1	filter element	01E. 60 - 01E. 150	01E. 170 - 01E. 450
2	1	O-ring	22 x 3,5 304341 (NBR) 304392 (FPM)	34 x 3,5 304338 (NBR) 304730 (FPM)
3	1	O-ring	54 x 3 304657 (NBR) 304720 (FPM)	75 x 3 302215 (NBR) 304729 (FPM)
4	1	support ring	61 x 2,6 x 1 304660	81 x 2,6 x 1 304581
5	2	O-ring	22 x 3 304387 (NBR) 304931 (FPM)	33,3 x 2,4 304380 (NBR) 314706 (FPM)
6	1	clogging indicator, visual	AOR or AOC see sheet-no. 1606	
7	1	clogging indicator, visual-electrical	AE see sheet-no. 1615	
8	1	clogging sensor, electrical	VS1 see sheet-no. 1617	
9	1	clogging sensor, electrical	VS2 see sheet-no. 1618	
10	1	O-ring	15 x 1,5	315357 (NBR) 315427 (FPM)
11	1	O-ring	22 x 2	304708 (NBR) 304721 (FPM)
12	1	O-ring	14 x 2	304342 (NBR) 304722 (FPM)
13	1	screw plug	20913-4	309817

item 13 execution only without clogging indicator or clogging sensor

4. Description:

Pressure filter of the series HPF are suitable for a working pressure up to 315 bar.

The pressure peaks are absorbed by a sufficient margin of safety. The HPF-filters are flanged to the mounting-surface.

The filter element consist of star-shaped, pleated filter material which is supported on the inside by a perforated core tube and is bonded to the end caps with a high-quality adhesive. The flow direction is from outside to the inside.

Filter elements are available down to 4 $\mu\text{m}_{(c)}$.

Internormen Product Line filter elements are known as elements with a high intrinsic stability and an excellent filtration capability, a high dirt-retaining capacity and a long service life.

Internormen Product Line filter are suitable for all petroleum based fluids, HW-emulsions, most synthetic hydraulic fluids and lubrication oils.

Internormen Product Line filter elements are available up to a pressure difference resistance of Δp 160 bar and a rupture strength of Δp 250 bar.

The internal valves are integrated into the centering pivot for the filter element.

After reaching the opening pressure the by-pass valve causes that an unfiltered partial flow passes the filter. With the reverse valve a protection of the filter element is given when having a reverse flow inside the filter. The reverse flow will not be filtered.

5. Technical data:

temperature range:	-10°C to +80°C (for a short time +100°C)
operating medium:	mineral oil, other media on request
max. operating pressure:	315 bar
test pressure:	450 bar
connection system:	manifold mounted
housing material:	C-steel
sealing material:	Nitrile (NBR) or Viton (FPM), other materials on request
installation position:	vertical

Classified under the Pressure Equipment Directive 97/23/EC for mineral oil (fluid group 2), Article 3, Para. 3.

Classified under ATEX Directive 94/9/EC according to specific application (see questionnaire sheet-no. 34279-4).

6. Symbols:

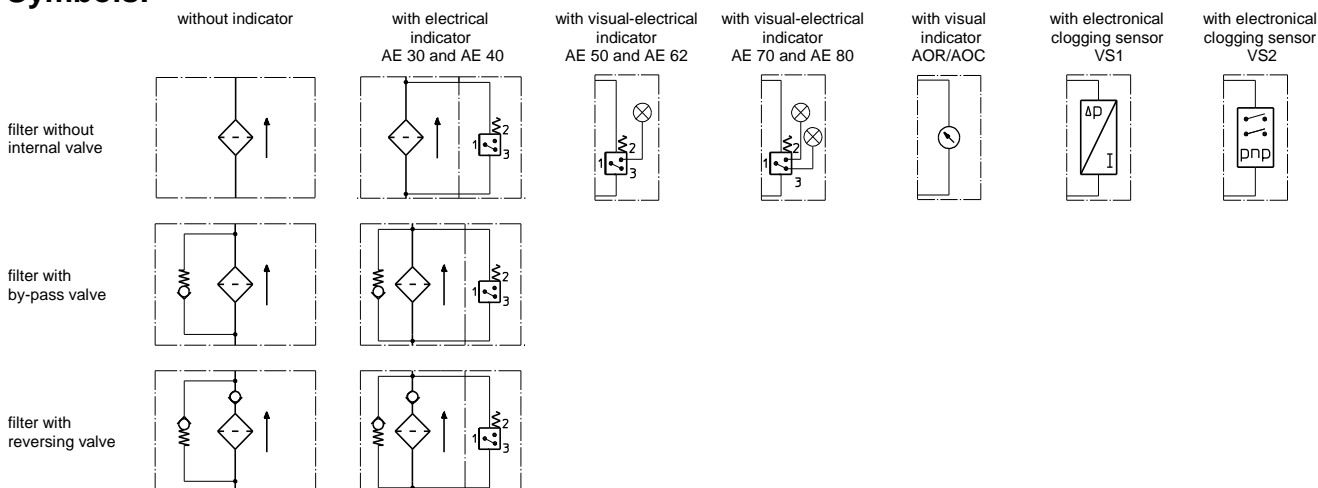

7. Pressure drop flow curves: Precise flow rates see 'Interactive Product Specifier' respectively Δp -curves ; depending on filter fineness and viscosity.

8. Test methods:

Filter elements are tested according to the following ISO standards:

ISO 2941	Verification of collapse/burst resistance
ISO 2942	Verification of fabrication integrity
ISO 2943	Verification of material compatibility with fluids
ISO 3723	Method for end load test
ISO 3724	Verification of flow fatigue characteristics
ISO 3968	Evaluation of pressure drop versus flow characteristics
ISO 16889	Multi-pass method for evaluating filtration performance